

Quick Start Guide

INSTEON® Micro Open/Close (Shutter)
Model: 2444-222/2444-422/2444-522

What's Needed

- Slotted #1 screwdriver
- Philips screwdriver
- Voltage meter
- Wire cutter/stripper

Installing Micro Module

Installation should only be performed by a qualified electrician or a homeowner who is familiar and comfortable with electrical circuitry. If you have questions, consult an electrician or call the INSTEON Support Line at 866-243-8022

- 1) Write down the INSTEON ID found on the back of the unit (XX.XX.XX)
 - 2) Turn off breaker/fuse and verify that the power is off
 - 3) Disconnect wires from existing switch, fixture or outlet and prep all wires to be connected to Micro module, with 3/16" (5mm) of bare wire on the ends
 - 4) Connect wires per diagram which corresponds to your installation
- Note: sense lines carry very low current (~0.35mA 240V, ~0.17mA for 120V)

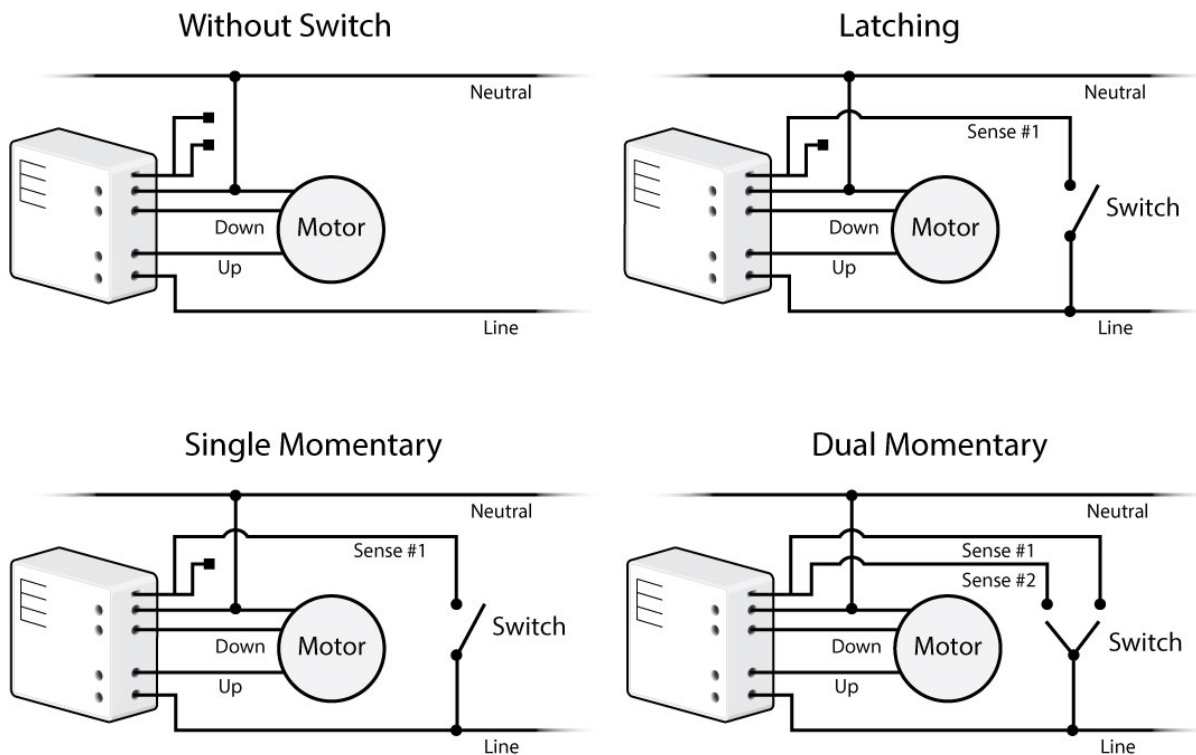
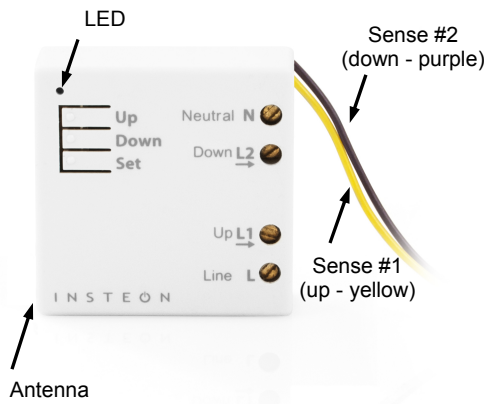

- 5) After ensuring wires are firmly connected and that there is no exposed wire, turn on breaker/fuse
After a few seconds, Micro module LED will turn green
- 6) Test by tapping Micro module up/down buttons
Motor will respond accordingly
Micro Module LED will turn green when motor is moving up/open and stay green until the down button is pressed
Micro Module LED will turn red when motor is moving down/closed and stay red until the up button is pressed
- 7) If installing a single momentary or dual momentary switch
 - a) Press and hold set button until it beeps
LED will start blinking green
 - b) Press and hold set button until it beeps a second time
LED will start blinking red

- c) Press and hold set button until it beeps a third time
LED will start blinking green
- d) Perform the step that applies
 - For single momentary: slowly tap set button four times
LED will continue blinking green
 - For dual momentary: slowly tap set button five times
LED will start double-blinking green
 - To switch back to latching: slowly tap set button six times
LED will start blinking green
- e) Once the mode is selected, press and hold set button until it double-beeps
LED will stop blinking and turn green if motor is up/open or red if motor is down/closed

Calibrate Micro Module

Once wired in, you need to calibrate Micro module for the time it takes for your application—shutters, blinds, projector screens, etc.—to fully raise/lower or open/close. Do not walk away during the calibration process as your set button taps will determine the timing. These settings can also be configured remotely via software (sold separately).

- 1) Press and hold set button until it beeps
LED will start blinking green
- 2) Press and hold set button until it beeps again
LED will start blinking red
- 3) Press and hold set button until it beeps a third time
LED will start blinking green
- 4) Press and hold set button until it beeps a fourth time
LED will start blinking red
- 5) Slowly tap set button twice
LED will continue blinking red
- 6) Press and hold set button until it beeps
Motor will begin travelling one direction
- 7) As soon as motor is fully lowered (or raised), tap set button
Motor will begin travelling the opposite direction
- 8) As soon as motor is fully raised (or lowered), tap set button
Micro module will double-beep

Reverse Motor Direction

For some applications, such as a projector screen, you want the connected motor to lower or close your connected screen or blinds when you press the up button or send an on command. Or you may have accidentally wired Micro module into the motor wrong. However, you don't have to rewire Micro module to fix it. Follow these steps to reverse the motor direction in response to commands (i.e., an on command will close/lower while an off command will open/raise).

- 1) Press and hold set button until it beeps
LED will start blinking green
- 2) Press and hold set button until it beeps again
LED will start blinking red
- 3) Press and hold set button until it beeps a third time
LED will start blinking green
- 4) Press and hold set button until it beeps a fourth time
LED will start blinking red
- 5) Slowly tap set button three times
LED will continue blinking red
- 6) Press and hold set button until it double-beeps
- 7) Test by tapping connected switch up and down
Motor will now operate in the reverse direction

Make Micro Module a Responder

- 1) Press and hold controller set button until it beeps
Controller LED will start blinking
- 2) You will have four minutes to complete the next steps before linking mode times out
Adjust motor connected to Micro module to desired brightness level
- 3) Press and hold Micro module set button until it double-beeps
Controller will double-beep and its LED will stop blinking
- 4) Test link by tapping controller button on and off or pressing and holding to brighten/dim
The motor connected to Micro module will respond appropriately

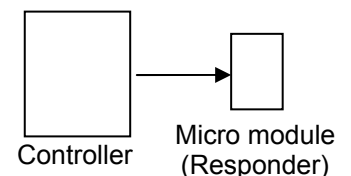

Make Micro Module a Controller

These settings can be configured remotely via software (sold separately). You can also add Micro module to your network manually by following the instructions below. *Note: you must perform these steps before reinstalling the wall switch.*

- 1) Press and hold Micro module set button until it beeps
Micro module LED will start blinking green
- 2) You will have four minutes to complete the next steps before linking mode times out
Adjust responder to desired state
- 3) Press and hold responder set button until it double-beeps
Micro module will double-beep and its LED will stop blinking
- 4) Test link by tapping switch connected to Micro module to turn up/down
Responder will respond appropriately

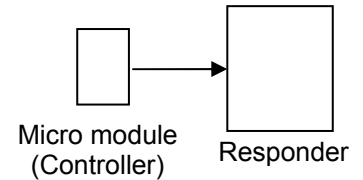

Assign an X10 Address

- 1) Press and hold Micro module set button until it beeps
Micro module LED will start blinking green
- 2) Send the X10 address 3 times (with or without commands)
Example: A1-A1-A1-AON or A1-AON-A1-AON-A1-AON
Micro module will double-beep and its LED will stop blinking
- 3) Test by sending X10 on and off commands
The motor connected to Micro module will respond appropriately

Owner's Manual and Tech Support

Visit: <http://www.insteon.com/support> for complete manual, online tech support and latest product documents.

Call: INSTEON Support Line at 866-243-8022

FCC Compliance

This device complies with FCC Rules Part 15. Operation is subject to two conditions: (1) This device may not cause harmful interference, and (2) This device must accept any interference that may be received or that may cause undesired operation.

The digital circuitry of this device has been tested and found to comply with the limits for a Class B digital device, pursuant to Part 15 of the FCC Rules. These limits are designed to provide reasonable protection against harmful interference in residential installations. This equipment generates, uses and can radiate radio frequency energy and, if not installed and used in accordance with the instructions, may cause harmful interference to radio and television reception. However, there is no guarantee that interference will not occur in a particular installation. If

this device does cause such interference, which can be verified by turning the device off and on, the user is encouraged to eliminate the interference by one or more of the following measures:

- Reorient or relocate the receiving antenna of the device experiencing the interference.
- Increase the distance between this device and the receiver.
- Connect the device to an AC outlet on a circuit different from the one that supplies power to the receiver.
- Consult the dealer or an experienced radio/TV technician.

WARNING! Changes or modifications to this device not expressly approved by the party responsible for compliance could void the user's authority to operate the equipment.